

2

1

B

B

Trigger Hanger Screw and
Cocking Piece Set Screw
Must Be Secured With Blue
Loctite Prior to Final Assembly

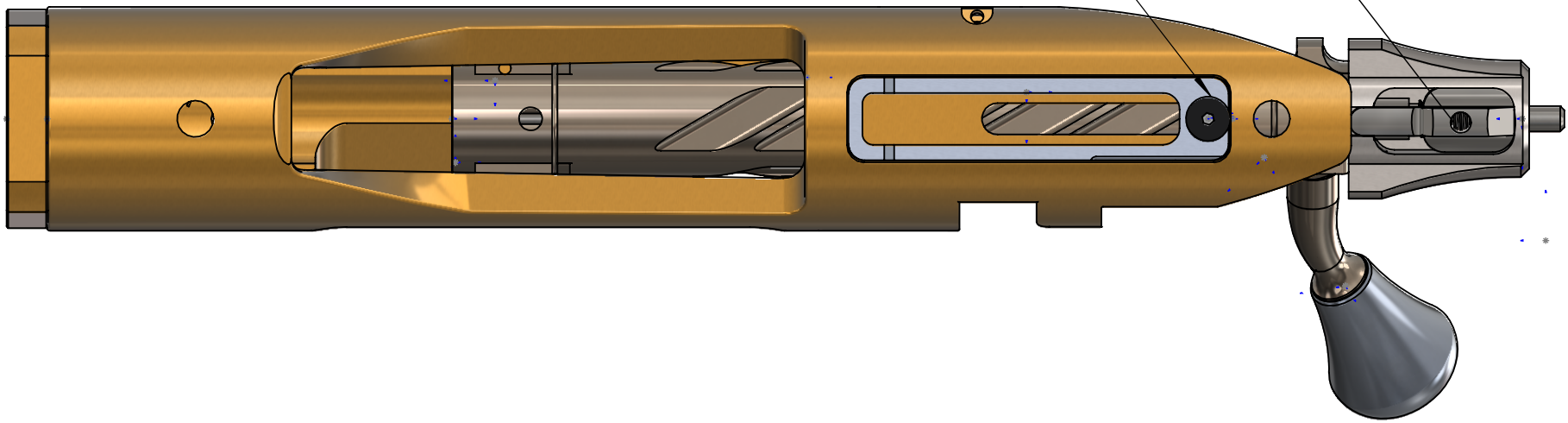

A

A

	NAME	DATE	Mack Brothers LLC		
DRAWN	SSM	6/28/18			
CHECKED			TITLE:		
ENG APPR.			EVO Action		
MFG APPR.					
Q.A.			SIZE	DWG. NO. 1	REV
COMMENTS:			A		1
			SCALE: 1:1	WEIGHT:	SHEET 1 OF 1

2

1

MACK BROTHERS EVO BOLT ACTION RECEIVER

WARNING

ALWAYS INSURE THE FIREARM IS UNLOADED AND ON SAFE

1. Fitting a barrel to the receiver must be performed by a competent gunsmith and the threaded tenon specifications supplied should be confirmed before any barrel and chamber fitting is performed.

LIMITED LIFETIME WARRANTY

2. This warranty covers any defects in workmanship and materials for the lifetime of the original owner. This warranty does not cover damage to the firearm caused by hand-loaded ammunition, misuse, negligence, abuse, modifications not related to manufacturing defects.

DISCLAIMER OF LIABILITY

3. Mack Brothers assumes no liability for damage and or injuries that result in whole or in part from improper installation, product malfunctions, negligent, criminal, improper use, and reloaded or defective ammunition.

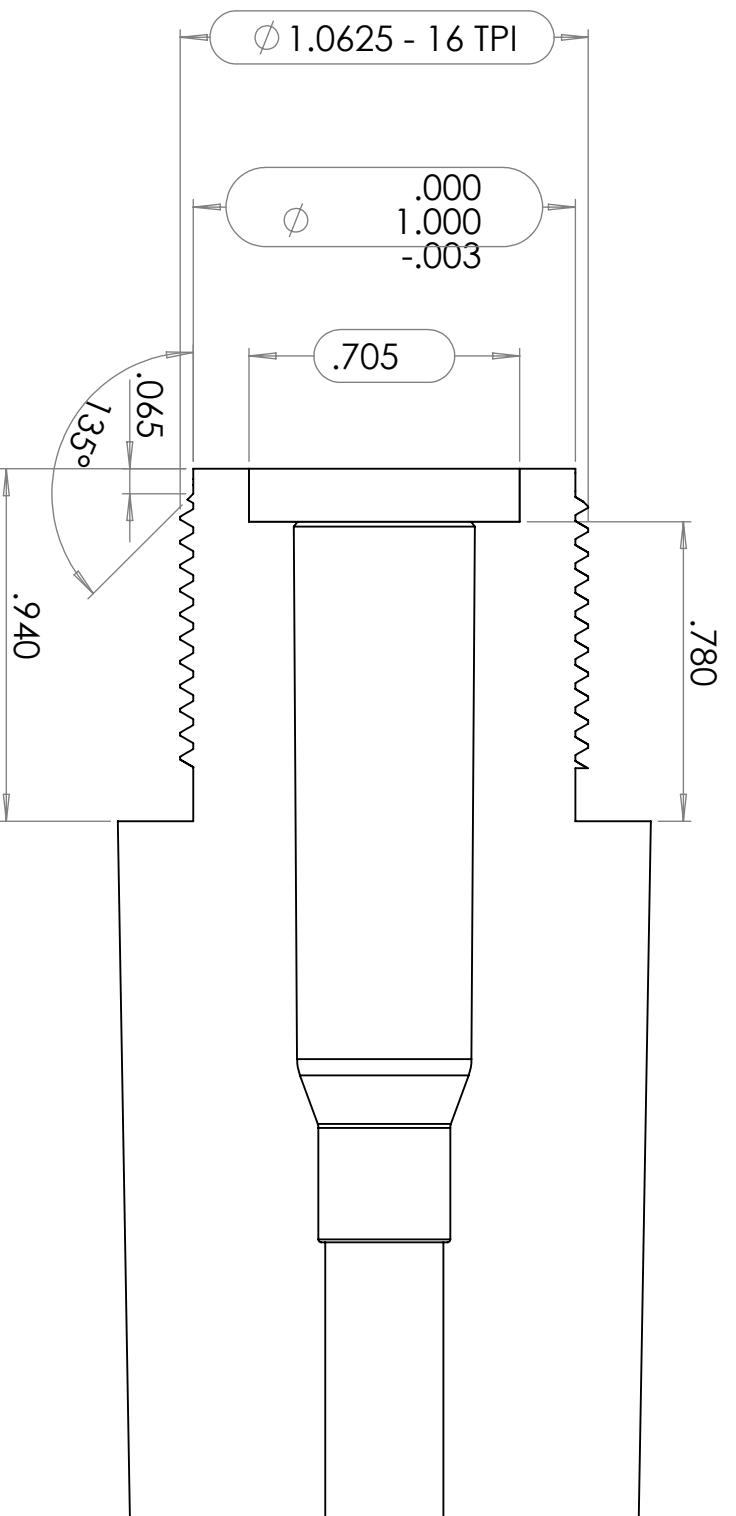

UNLESS OTHERWISE SPECIFIED: DIMENSIONS ARE IN INCHES		DRAWN	NAME	DATE	MACK BROS TITLE: EVO BOLT ACTION RECEIVER	
SURFACE FINISH $\sqrt{16}$ FRACTIONAL: ±.164" ANGULAR: MACH ±0.1 BEND ±0.5 TWO PLACE DECIMAL ±.005 THREE PLACE DECIMAL ±.002 FOUR PLACE DECIMAL AS NOTED INTERPRET GEOMETRIC TOLERANCING PER: ASME Y14.5-2009		CHECKED	RM	3/24/2021		
MATERIAL		ENG APPR.		MFG APPR.		COMMENTS: NO BURRS OR SHARP EDGES ALLOWED, UNLESS NOTED INSIDE CORNER RADIUS SHALL NOT BE LARGER THAN .010
FINISH		G.A.		SCALE: 1:1		
DO NOT SCALE DRAWING		NEXT ASSY		USED ON		WEIGHT:
APPLICATION		REVISION		SHEET 1 OF 2		REV

PROPRIETARY AND CONFIDENTIAL
 THE INFORMATION CONTAINED IN THIS
 DRAWING IS THE SOLE PROPERTY OF
 HORIZON MACHINE and MACK BROS.
 ANY REPRODUCTION IN PART OR AS A
 WHOLE WITHOUT THE WRITTEN PERMISSION
 OF HORIZON MACHINE and MACK BROS
 IS PROHIBITED.

A

B

C

D

A

B

C

D

2

1

Extractor Removal



Removal:

With bolt face toward you, slide flat head screw driver under extractor lip and push extractor away from bolt. Be careful not to mar the face of the bolt. While extractor is being pushed away from bolt, lift extractor up to unseat the extractor and continue lifting up until the extractor is completely removed.

B

B

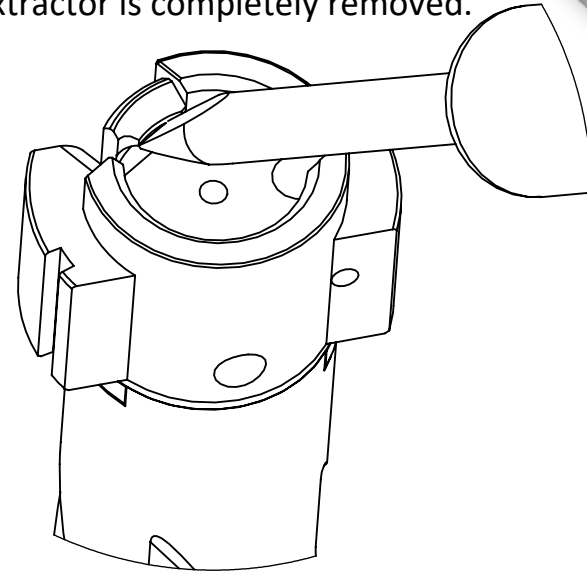
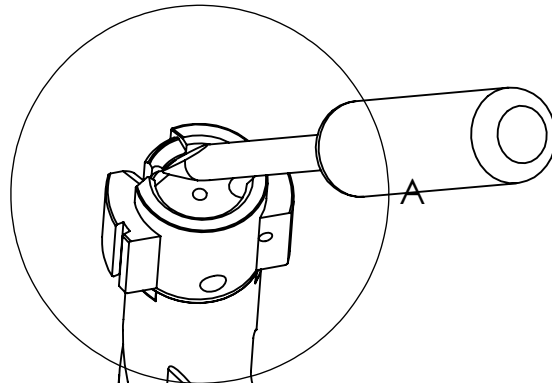

DETAIL A
SCALE 2 : 1

Replacement (No Tools Needed):

To replace extractor, insert extractor into bolt body groove. Press into place until extractor is seated flush with bolt face.

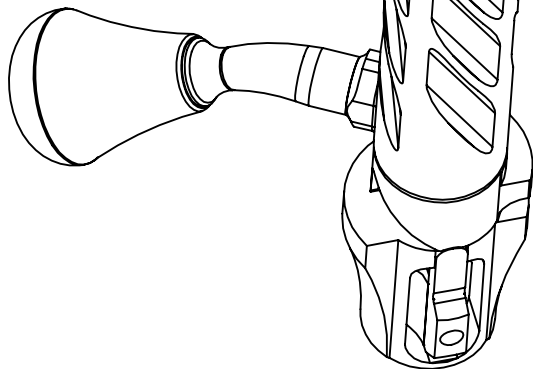

A

A

	NAME	DATE	Mack Brothers		
DRAWN	SSM	8/11/17			TITLE:
CHECKED			EVO Bolt Instructions		
ENG APPR.					
MFG APPR.					
Q.A.					
COMMENTS:			SIZE	DWG. NO. 2	REV
			A		1
	SCALE:	WEIGHT:	SHEET 2 OF 2		

2

1

EVO Bolt Instructions



Removing the firing pin assembly from the cocked position, Figure 1:

With the bolt shroud facing you, rotate the shroud and firing pin assembly 90deg. Clockwise. Firing pin assembly will pop out as shown in Figure 2.

B

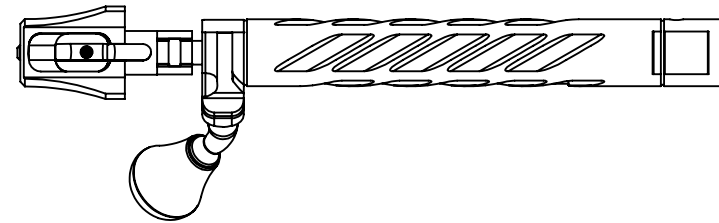
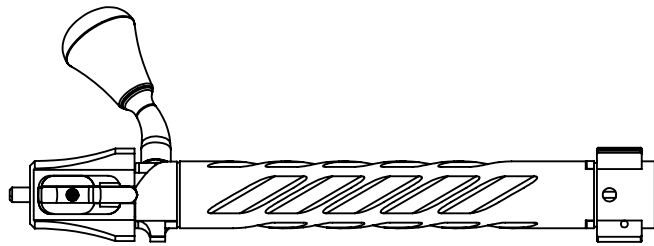

B

Firing pin removal:

Remove both set screws using a 1/16" hex wrench. Screws are 6-32 set screws. To remove firing pin, unthread firing pin from cocking piece after set screws are removed. **Spring and pin are under spring load.**

When replacing the firing pin, align indent in firing pin thread with hole in cocking piece and secure with both set screws in the indent. **Use Blue Loctite on last set screw only.**

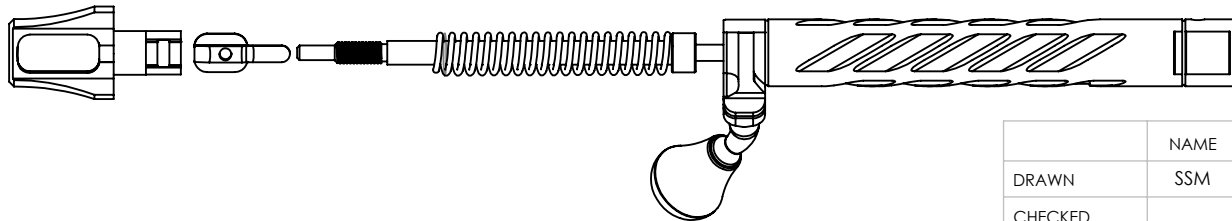

A

A

Disclaimer of Liability:

Mack Brothers assumes no liability for damage and or injuries that result in whole or in part from product malfunctions, negligent, criminal, improper use, improper installation, and reloaded or defective ammunition.

	NAME	DATE
DRAWN	SSM	8/11/17
CHECKED		
ENG APPR.		
MFG APPR.		
Q.A.		
COMMENTS:		

Mack Brothers		
TITLE:		
EVO Bolt Instructions		
SIZE	DWG. NO. 1	REV
A		1
SCALE: 1:2	WEIGHT:	SHEET 1 OF 2